

Department of Mechanical Engineering (Established in 2002)



B-TECH Laboratory Manual

For

**B. Tech - I Sem
ENGINEERING MECHANICS LAB II-80305**

Academic Year 2019-20



**Malla Reddy Engineering College
(Autonomous)**



(An Autonomous institution, Autonomy granted by UGC and affiliated to JNTUH, Accredited by NAAC with 'A' Grade,
Accredited by NBA (2008-11) & Recipient of World Bank Assistance
under TEQIP phase – II S.C.1.1 for the period (2011-14))
Maisammaguda, Dhulapally (Post. Via. Kompally), Secunderabad – 500 100.

MR-18 80305 ENGINEERING MECHANICS LAB

List of Experiments	Page
1. Triangle law and polygon law of forces apparatus.	3
2. Support reaction for a beam apparatus.	6
3. Coefficient of friction apparatus.	10
4. Flywheel apparatus.	12
5. Moment of disc apparatus.	14
6. Jib Crane	17
7. Equilibrium of non concurrent forces apparatus.	20
8. Universal force table.	24
9. Screw jack apparatus.	27
10. Compound pendulum.	31
11. Worm and worm wheel apparatus.	33
12. Differential wheel and axle apparatus.	36

EXPERIMENT NO-1

TITLE: Law of Polygon of Forces

OBJECTIVE:

To verify the law of polygon of forces for a numbers of coplanar forces in equilibrium.

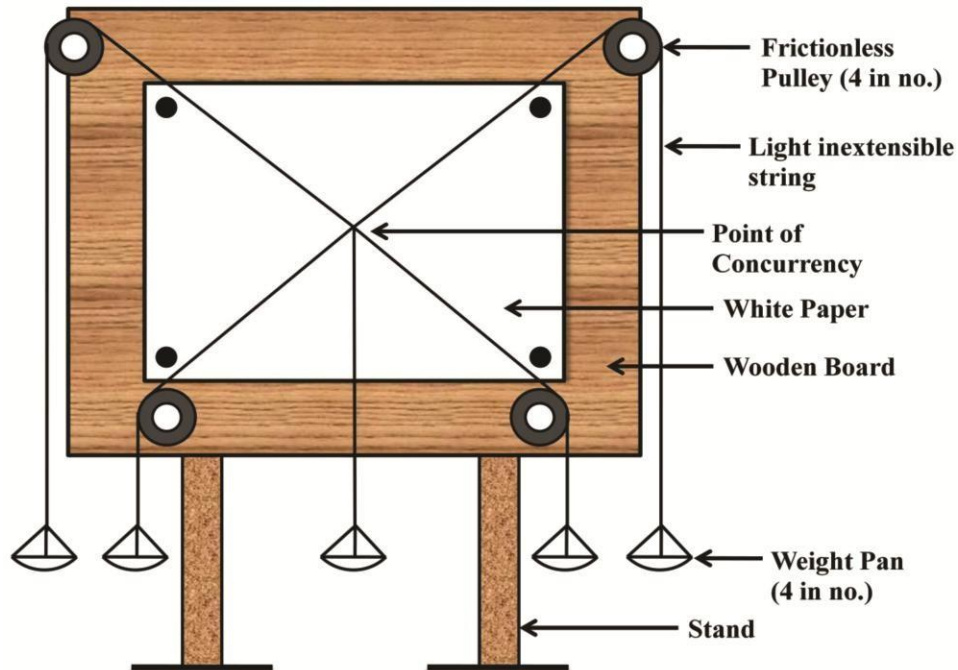

Figure 1.1: Labeled diagram of the apparatus

THEORY:

The Law of Polygon of Forces states that – if any number of coplanar concurrent forces can be represented in magnitude and direction by the sides of a polygon taken in order; then their resultant will be represented by the closing side of the polygon taken in opposite order”.

Also, if the forces form a closed polygon, then the system is in equilibrium. Fig. 1.2 and 1.3 shows a system of five forces F_1 , F_2 , F_3 , F_3 and F_5 . The forces are forming a closed polygon in the first figure, hence they are in equilibrium. In the second figure, the system is not in equilibrium, and the closing side, shown by dotted line, denotes the Resultant R of the force system.

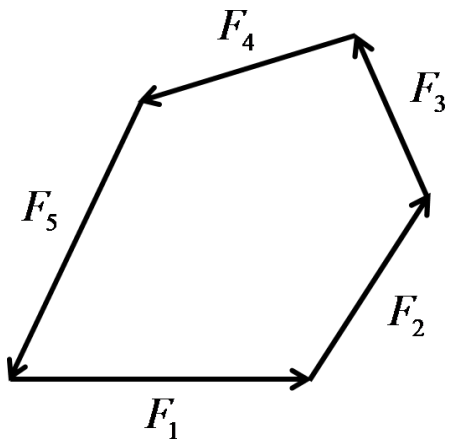

Figure 1.2

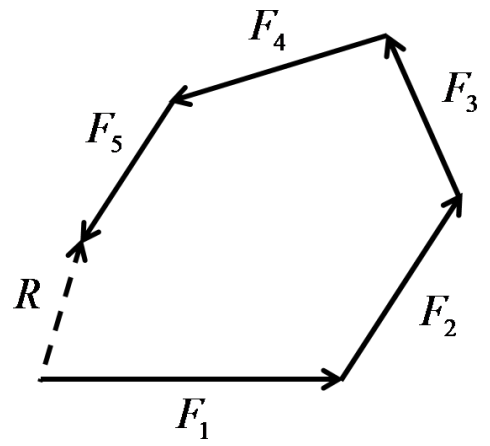

Figure 1.3



Figure 1.4: Experimental setup in the lab

PROCEDURE:

1. Set up the apparatus provided after measuring and recording the weights of the pans.
2. Put different weights on the pan (W_1 , W_2 , W_3 , W_4 and W_5) and let the system come to rest and then note their values.
3. Now, fix a sheet of paper on the drawing board and mark the central point (point where the strings meet and the directions of the string with pencil.
4. Remove the paper from the drawing board and draw the lines of actions of the forces.
5. Draw the force polygon by representing W_1 , W_2 , W_3 , W_4 and W_5 in magnitude and direction.
6. The polygon may not be closed. The error (unclosed distance of the polygon) is due to error in experimentation and the friction in various moving parts.
7. Repeat the procedure 4 times and complete the experiment.

DATA PROVIDED:

The weight of the Pan = 46.649 gm

TABULATION OF RESULTS:

Observation Number	Weights in different pans (gm)				Resultant (Error) (gm)	
	W_1	W_2	W_3	W_4	Analytical Method	Graphical Method
1						
2						
3						
4						

CALCULATIONS:

For each observation, first do the Analytical Calculation, and then find the result using Graphical Method. For graphical method, draw one Space Diagram and one Vector Diagram. Do mention the Scale for the Vector Diagram. Do attach the Sheet of Paper, on which the experiment is performed, with this journal.

EXPERIMENT NO-2

PARALLEL FORCE APPARATUS

AIM :-To verify the condition of equilibrium by finding reactions at the support of a beam.

APPARATUS :- A Calibrated beam supported on The compression balance, weights, and hangers.

DESCRIPTION: - It consists of a wooden beam having equivalent grooves across its length at 10cm intervals. The beam is supported by 2 balances. The distance of the weight from the support can be suitably adjusted. The experimental values of the reaction can be directly known from the balance.

THEORY :- The condition of the equilibrium are:

- 1) The algebraic sum of the horizontal components of all forces must be zero.
- 2) The algebraic sum of vertical components of all forces must be zero.
- 3) The algebraic sum of moment of all forces about any point must be zero.

PROCEDURE :-

1. Study the working of the apparatus.
2. Note down the zero errors if any.
3. Note down the self-weight of the beam.
4. Apply weighs on hangers from left & hold down the position from the left hand support.
5. Take five such readings carefully at different points, different reading with different position of load.
6. Calculate reading on the support by applying condition of equilibrium.

OBSERVATIONS :-

1. Self weight of beam = _____ N.
2. Span of beam = _____ Cm.
3. Initial reading of left balance = _____ N.
4. Initial reading of right balance = _____ N.
5. C.G measured from L.H.S. = _____ Cm.
6. Weight of the hanger = _____ N.

OBSERVATION TABLE:-

sr. no.	Weight applied (N)			Distance from L.H.S cm.			Observed reading		Calculated reading	
	W1	W2	W3	X1	X2	X3	R1(N)	R2(N)	R1(N)	R2(N)
1										
2										
3										
4										
5										

CALCULATION

:-

$$R2 = \frac{(W1X1 + W2X2 + W3X3)}{L} =$$

$$R1 = [(W1+W2+W3) - R2] =$$

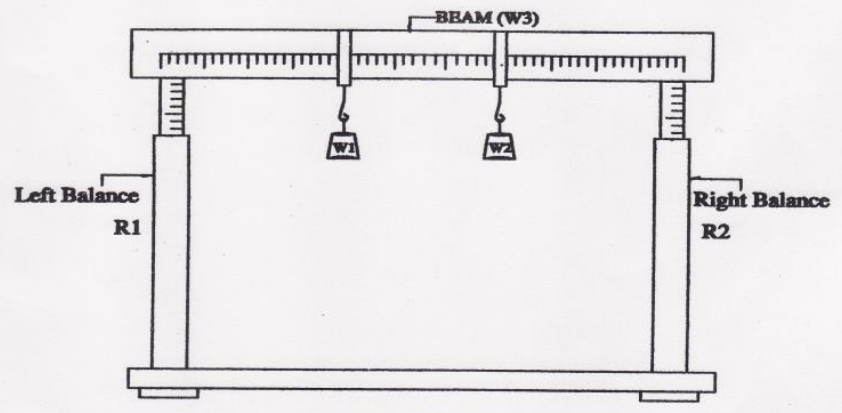

BEAM REACTION

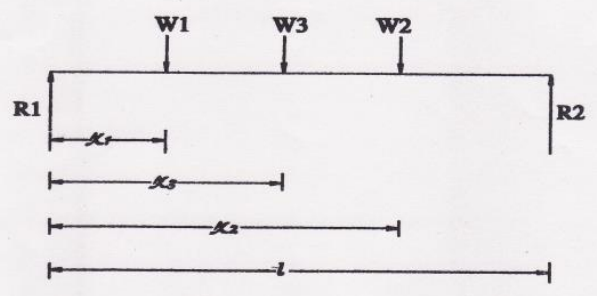

PRECAUTION :

The readings should be taken carefully.

The weighs should be added carefully.

CONCLUSION:

**It is observed that the observed values and calculated values are same.
It can be concluded that the experiment Carried out is correct.**

EXPERIMENT NO-3

OBJECTIVE-

To measure the co-efficient of friction of different surfaces.

APPARATUS REQUIRED-

1. Inclined plane.
2. Sliding boxes with different surfaces.
3. String.
4. Scale pan.

THEORY-

The co- efficient of friction can be found by three different ways on the inclined plane.

Method -1

The inclined plane is kept horizontal and the sliding box is given a horizontal pull P. In the limiting case, when the box just slides,

$$P = \mu w \text{ or } \mu = P/w.$$

Method -2

The inclined plane is kept in an inclined position and the sliding box is pulled upwards along the inclined plane by a force p. When the box just slides,

$$R = W \cos\theta$$

$$P = W \sin\theta + \mu W \cos\theta \text{ Or}$$

$$\mu = (P - W \sin\theta) / W \cos\theta$$

Method -3

The sliding box is kept in the horizontal plane, and is the plane is raised gradually until the box just slides. If θ is the angle when the box just slides,

$$W \cos\theta = W \sin\theta \text{ Or}$$

$$\mu = \tan\theta$$

PROCEDURE-

1. Take the inclined board with a glass surface.
2. Keep it horizontal initially and put the slider with steel base on it. Increase the inclination of the inclined board gradually till the slider just begins to slide on it.
3. Note the angle in this position. This is angle friction let it be θ_1 .
4. Now place some weights in the slider and repeat and experiment as before. Let the angle of inclination in this case be θ_2 .
5. Repeat the experiment as before with different weight in the slider each time. Note the corresponding angle of inclination of inclined Board and their mean. Let it be θ_0 . This is the then the coefficient of friction is (μ) given by $\mu = \tan \theta_0$.

PRECAUTIONS-

1. Note the time accurately to the fraction of a second.
2. Note the value of F when the motion just begins and wheel does not move with any acceleration.
3. Oil the bearing to reduce friction.
4. Overlapping of the string should be avoided.
5. Note the time thrice for the same weight (W).

OBSERVATION TABLE-

S. No-	Wt. of Box. (a)	Wt. in the box (b)	Total Weight $W=(a+b)$	Wt. of Pan (c)	Wt. in The pan (d)	Total Wt $P=(c+d)$	μ	Mean μ
RESULTS AND DISCUSSION-								

PRECAUTIONS-

1. Clean the two surfaces so no grease or sand sticking to the surfaces.
2. Increase the angle very slowly.
3. Particular region of the inclined board may be used.
4. The block should just begin to move, it should not move abruptly.

EXPERIMENT NO-4

OBJECTIVE-

To determine the moment of inertia of a flywheel about its own axis of rotation.

APPARATUS REQUIRED-

1. Knife-edge.
2. Connecting
3. Rod/pulley
4. Weighing scale
5. Ruler.

Moment of Inertia-

If m is any mass distances from a given line be r then $\sum mr^2$ is defined as the moment of inertia of the given line. Radius of Gyration. If this quantity is equal to Mk^2 . Where M is the total mass of the body then k is called the **radius of gyration** of the body about the given line. It is also called the swing-radius. It is assumed that the students are acquainted with the theorems on moment of inertia.

THEORY-

When a weight is suspended to the free end of a cotton string, which is wrapped round tin: shaft and the other end of which is tied to the shaft and it is allowed to fall to touch the ground then P.E. energy possessed by the falling weight has partly been used to give moment to the fly wheel and partly used in overcoming frictional resistance present in the bearings.

- Initial potential energy (P.E) = $W \times h$ when h is the height of the weight from the level ground.
- Initial kinetic energy (K.E) = 0. Final P.E = 0
- Final (K.E) = $\frac{1}{2} (w/g) v^2 + \frac{1}{2} I (w^2/g)$ where $\frac{1}{2} (w/g) v^2$ is the K.E. of the falling wt. And $\frac{1}{2} I (w^2/g)$ is the K.E. of the fly wheel and shaft combined and w is the final angular velocity of the wheel or of the shaft.

1. Work done due to frictional resistance = $f \times h$ where F is the force of force of friction acting tangentially to the shaft. From law of conservation of energy we can write $w \times h = \frac{1}{2} (w/g) v^2 + \frac{1}{2} I (w^2/g) + F \times h$

$$= \frac{1}{2} 2g (W - F) \times h$$

$$= \frac{1}{2} I = (W - F) \times 2gh - Wv^2 / w^2$$

But v (final velocity) r is given by the formula $(u+v)/2 = h/t$ where t is the time taken for the weight to fall a distance h so that h/t is average velocity.

$W = v/r$ where r is the radius of the shaft.

$$= \frac{1}{2} I = (W - F) \times 2gh - w (2h/t)^2 / (2h/t^2) \text{ gm cm}^2$$

PROCEDURE-

- Wrap the cotton string round the shaft and suspend a small weight (W) to the free end of the string. Go tri increasing this weight till the shaft just begins to rotate. This weight is the value of F , the frictional resistance.
- Mark the position of the string where it just “leaves the shaft when the weight (W) is held” at rest. Mark another position of the string where where it just leaves the shaft when the weight (W) has touched the earth-

- after it is allowed to fall. The distance between these two positions is the value of h.
- (Note this method is used when the vibrometer is not provided with the fly wheel).
- Place a weight (W) more than F and hold the. Pen in, this weight is placed. Release weight (w) and start the stopwatch simultaneously. Stop the watch as soon as the telling weight has touched the level ground. This gives the time (t).
- Measure the diameter of the shaft with the help of venire caliper at four places. Take their mean and find the radius (r) of the shaft.
- Repeat the experiment for different values of ‘W. take in this way about seven readings.
- Apply the formula proved in theory to calculate the value of I as W, F, t, h and r have been determined.

OBSERVATION-

- Diameter of the shaft = 1-----cm, 2----- cm, 3-----cm, 4 -----cm.
- Mean diameter =----- cm.
- Radius of the shaft (r) = -----cm.
- Factional resistance (F) = 1 -----kg, 2-----kg, 3-----kg, 4 ----- kg
- Mean F =----- kg.
- Distance between the marked position on the string (h) =-----cm.

S.No.	Falling Weight (W)	Time Taken (t)	$I = (W-F) \times 2gh - W (2h/t)^2 / (2h/t^2)$
1.			
2.			
3.			

RESULTS AND DISCUSSION-

Mean (I) =-----gm cm².

EXPERIMENT NO-5

To verify the law of moment by rotating disc apparatus.

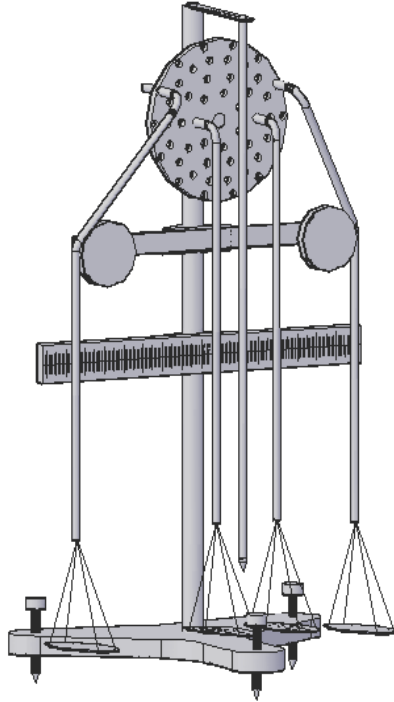

APPARATUS REQUIRED:-

1. Mirror scale (adjustable)
2. Two small pulley (adjustable)
3. Hollow disc (adjustable)
4. Four pans
5. Slotted weight
6. Plumb line

THEORY & FORMULA USED:-

The law of moment's states that if a number of coplanar forces acting on a rigid body keep it in equilibrium then the algebraic sum of their moments about any point in their plan is zero.

In the moments disc apparatus, we use the hollow disc, pulleys, threaded pan, mirror scale, plumb line. All these things are adjustable. Due to use these apparatus make to ensure that the level of

fixing threaded pan in a hollow disc should be equal. Requirement of plumb line to adjusting the apparatus at equal level in any positions.

The hollow disc & pulleys are moving either clockwise or anti-clockwise direction. All parts are adjusting on the straight beam which should be rigidly fixed on the base of the apparatus.

PROCEDURE:-

- (1) Put weights in the two pans A and B. such that W^1 is the weights in the pan A plus weight of the pan & W^2 weight in the pan B plus weight of pan B. Note down W^1 & W^2 .
- (2) Rotating disc should be placed at a centre point note the thread are showed at zero on the scale
- (3) Note down the distance X^1 and X^2 .
- (4) Now ($W^1 \times X^1$) will be equal to ($W^2 \times X^2$) that is both the clockwise and anticlockwise and anticlockwise moments will be equal.
- (5) Take different sets of reading and find out the value of both the moments.
- (6) If both the moment is not equal then find out the percentage error between the clockwise moment and the anti clockwise moment.

OBSERVATIONS:-

W^1 = weight in the pan A

W^2 = weight in the pan B

X^1 = distance from the centre point of the apparatus to the end of thread shadow show in the mirror scale of which pan A

X^2 = distance from the centre point of the apparatus to the end of thread shadow show in the mirror scale of which pan B

S. No.	Weight of pan + Weight in pan (W^1)	Weight of pan + Weight in pan (W^2)	X^1 (c.m.)	X^2 (c.m.)	Percentage Error
1.	225	225	17	17	0
2.	225	225	17	16.6	0.4
3.	525	525	17	16.6	0.4

PRECAUTIONS:-

- (1) Weights should be placed in the pans A and B gently.
- (2) Take in to the account the weights of the pan.
- (3) Lubricate the apparatus.
- (4) Distance should be noted down carefully.

EXPEIMENT NO-6

JIB CRANE

- AIM** :- To Verify Lami's theorem by finding the forces in the Jib-crane.
- APPRATUS** :- Jib-crane apparatus consists of a vertical part, the chain, Compression jib, weights, scale spring etc.
- THEOREM** :- Lami's Theorem:
- If three forces are acting on a system & if it is Equilibrium, then these forces can be represented by three sides of triangle & each force is proportional to the sine of the angle between the remaining two forces.
- PROCEDURE** :-
- 1) Carefully study the working of apparatus.
 - 2) Note down the error, if any on the spring balance.
 - 3) Apply weights at the apex points using a hanger frame.
 - 4) Note-down the readings on the spring balance.
 - 5) Note down the length of vertical part, tie & jib as well as horizontal balance.
 - 6) Draw the space diagram of jib crane using suitable scale.
 - 7) Measure the angles at the apex point from the diagram.
 - 8) Using Lamin's theorem find the forces in the jib & tie.
 - 9) Draw the triangle of forces to suitable scale.
 - 10) Find the forces in the jib & tie from the triangle of forces by graphical method.
- PRECAUTIONS** :-
- 1) The initial readings should be taken carefully.
 - 2) Measures the angles accurately.

OBSERVATIONS:

- 1) Initial reading of tie = N.
 2) Initial reading of jib balance = N.

OBSERVATION TABLE:-

Sr. No.	Load (N) W	Length in Cm.			Observed Reading		Corrected Reading	
		JIB	TIE	POST	JIB(N)	TIE(N)	JIB(N)	TIE (N)
1								
2								
3								
4								
5								

Sr. No.	α	β	θ	Value From Graph (N)	
				JIB	TIE
1					
2					
3					
4					
5					

SAMPLE CALCULATION :- When $W = \underline{\hspace{2cm}}$ N.

$$\frac{W}{\sin \beta} = \frac{T}{\sin \alpha} = \frac{J}{\sin \theta};$$

T = Tension in Tie = N.

J = Compression in Jib = N

CONCLUSION

∴ The experimental value of forces in the jib & tie are nearly same as calculated from lami's theorem & forces triangle. Thus, Lami's theorem is verified.

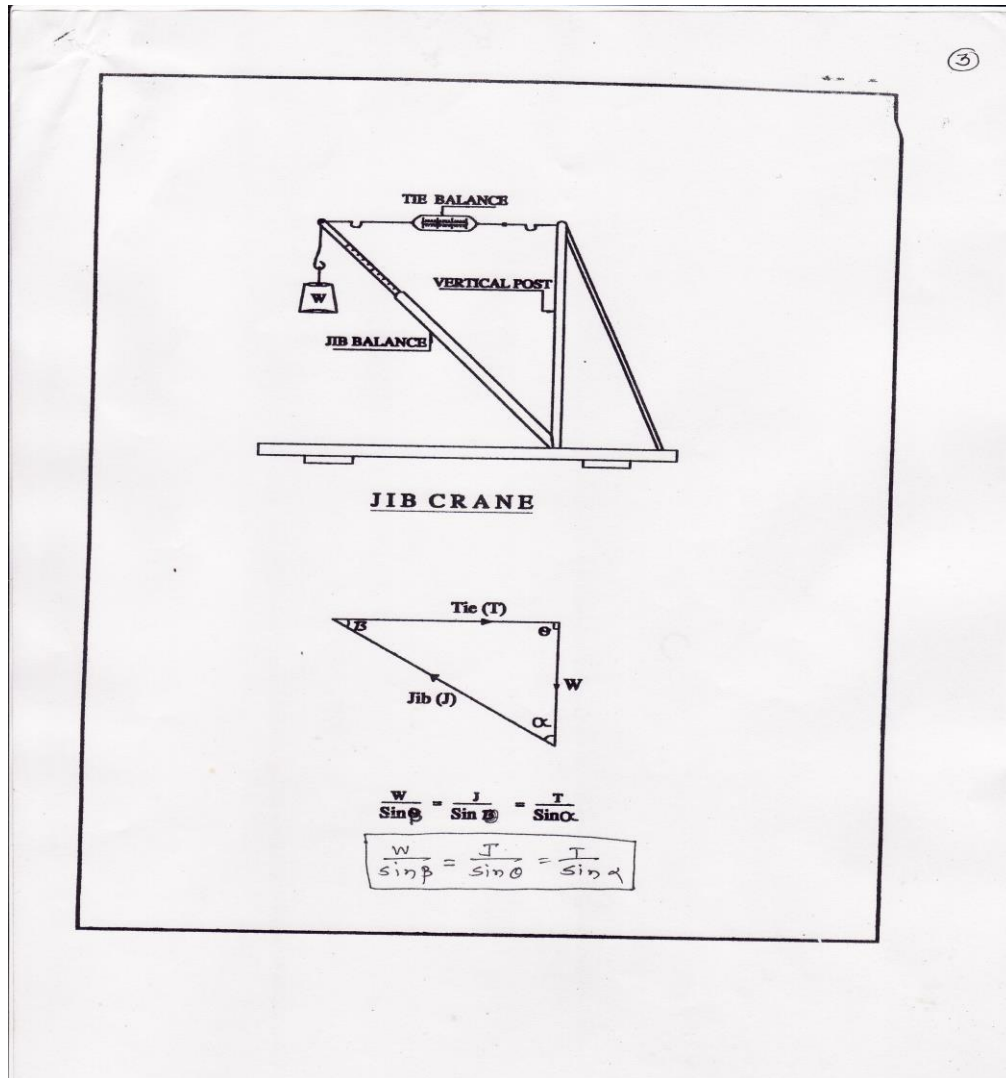

EXPERIMENT NO-7

POLYGON LAW OF COPLANAR FORCES (CONCURRENT)

AIM:- To verify the conditions of equilibrium of a coplanar concurrent force system and to find the resultant of the force system when other forces are known.

APPARATUS:- Polygon of Force Apparatus, Weights, Strings, Drawing Paper and Mirror Piece.

THEORY:- The Conditions of equilibrium of coplanar concurrent force system is given by the equations as

$$\sum F_X = 0$$

$$\sum F_Y = 0$$

Where $\sum F_X$ and $\sum F_Y$ are the sum of Horizontal and vertical components of the given forces along the 'X' and 'Y' axis respectively.

PROCEDURE:-

- 1) Fix a Drawing sheet on the Board. Make a knot of 5 strings and pass 4 of the 5 strings over the pulleys mounted on the board. Load them with weights. To the other end of the fifth string, tie a pan and add some known weight to it till the system attains equilibrium position in a particular direction.
- 2) Since all the five strings are meeting at the knot, we can say that Tensile forces in the strings are concurrent and they are in equilibrium. With the help of pencil, make the directions of the forces and centre point of the force system on the paper.
- 3) Remove the drawing paper and make 'X' and 'Y' axis at the point of concurrency. Calculate the angles made by the forces with respect to X axis. Resolve all the forces along X and Y axis and calculate $\sum F_X$ and $\sum F_Y$, which should be equal to zero for a perfect case of equilibrium. Repeat the procedure by changing the weights in all the 5 directions.
- 4) A force polygon is drawn with all the five concurrent forces. Ideally, a closed polygon is to be obtained, if there is no error.
- 5) With the help of above information, calculate fifth force by knowing the four forces, which is nothing but a Resultant to the four forces in magnitude and direction.

OBSERVATION TABLE :

SET NO.	FORCE	MAGNITUDE (N.)	ANGLE MADE BY THE FORCE WITH X-Axis 'θ'	F X = (FCOSθ)	Σ F x	F Y = (FSIN θ)	Σ F Y
I	F1		θ1=				
	F2		θ2=				
	F3		θ3=				
	F4		θ4=				
	F5		θ5=				
II	F1		θ1=				
	F2		θ2=				
	F3		θ3=				
	F4		θ4=				
	F5		θ5=				

Resultant of Four Forces:

Resultant of the four forces i.e F1, F2, F3 and F4 is given by the equation as

$$R = F_5 = \sqrt{R_x^2 + R_y^2}, \text{ where}$$

$$R_x = (F_1 \cos \theta_1 + F_2 \cos \theta_2 + F_3 \cos \theta_3 + F_4 \cos \theta_4)$$

$$R_y = (F_1 \sin \theta_1 + F_2 \sin \theta_2 + F_3 \sin \theta_3 + F_4 \sin \theta_4)$$

$$F_5 = \sqrt{R_x^2 + R_y^2} =$$

SAMPLE CALCULATION:-

F1 =

F2 =

F3 =

F4 =

F5 =

θ1=

θ2=

θ3=

θ4=

θ5=

$$\sum F_x =$$

$$\sum F_y =$$

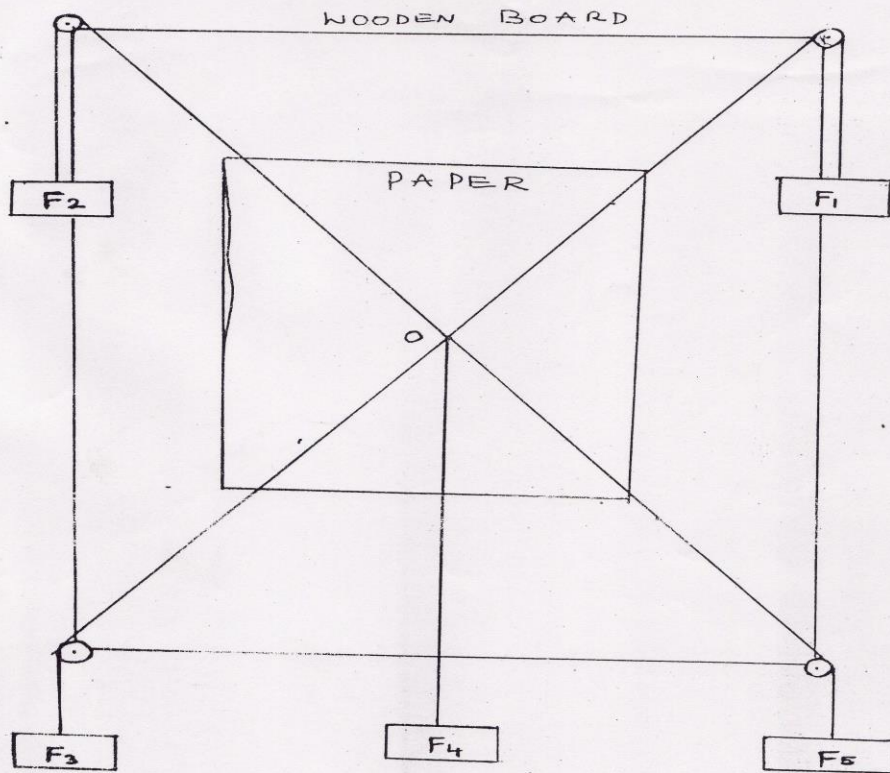

POLYGON LAW OF COPLANAR FORCES
(CONCURRENT)

RESULT :-

The conditions of equilibrium of coplanar concurrent force system is verified, as the error is very low and negligible.

EXPERIMENT NO-8

UNIVERSAL FORCE TABLE

AIM:-

To Verify The Universal Force Table.

APPARATUS – Universal force table apparatus complete with freely moving and **adjustable** guide pulleys (Fig. 1), a ring with five strings, weight hangers, weight etc.

COMPONENTS:-

- Thread Pulley
- Slotted Weight
- Thread/Rope
- Level Screw
- Central Ring

THEORY : Polygon law of forces states that if a number of coplaner forces acting on a particle are represented in magnitude and direction by the sides of a polygon taken in order, then their resultant is represented in magnitude and direction by the closing side of the polygen taken in order.

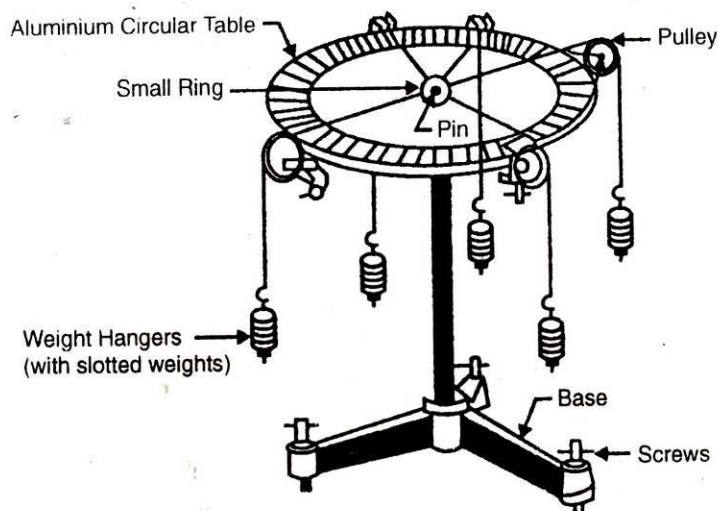

(FIG. 1 (f)) Universal Force Table

PROCEDURE (It can be done on Gravesand Apparatus also)

1. Clamp the pulleys to the graduated disc of the force table and make it horizontal by adjusting the screws at its base.
2. Tie each end of five strings to the circumference of a small ring and place it round the pin. Attach the other ends of the strings to the weight hangers, hanging over the pulley.
3. Put small weights on the weight hangers in such a manner that the ring is placed symmetrically round the axle and it does not touch the axle of the apparatus or the plane surface of the graduated disc.
4. Note the position of any one string on the disc and then find the angles between all the strings as $\theta_1, \theta_2, \theta_3, \theta_4$ and θ_5 .
5. Note down the magnitude of weights W_1, W_2, W_3, W_4 and W_5 acting on the ring.
6. Draw the space diagram of the forces $F_1 = W_1, F_2 = W_2, F_3 = W_3, F_4 = W_4$ and $F_5 = W_5$ as shown in Fig. 2 (a).
7. Draw the vector diagram abcde as shown in Fig. 2 (b). If the last force F_5 represented by the side ea falls short or is greater than the side which would complete the polygon, then measure the side which would complete the polygon and find the percentage error between the force F_5 and the force required to complete the polygon.

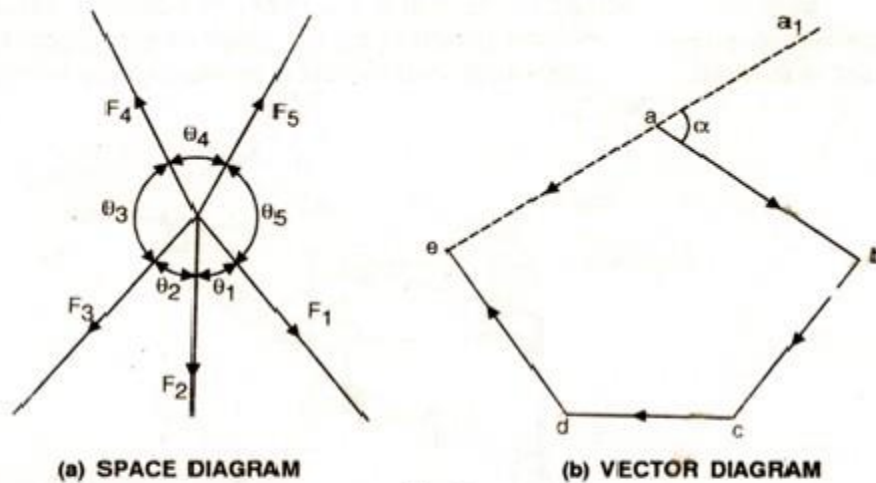

Fig. 2

8. Measure the angle $a'ab$ i.e. α which would be equal to θ_5 . If they are different, then find the percentage error between these angles taking any of them to be true angle.
9. Repeat the experiment with different set of weights.

PRECAUTIONS

1. The graduated disc should be made horizontal by adjusting the screws at its base. This can be checked with the help of a spirit level.
2. The ring should not touch the pin or the disc.
3. The pulleys should be frictionless, i.e. well lubricated.
4. The positions of the strings should be carefully noted only after the system has come to rest completely.

Observation Table:

No	Forces Or Weights Suspended (R ₁)					
	F=W ₁	F=W ₂	F=W ₃	F=W ₄	F=W ₅	F=W ₆
1	0	200	200	350	250	250

Sr No	Angles () And Distances Ring To Wheel (cm)										RESULTANT (R)
	<i>1</i>	L ₁	<i>2</i>	L ₂	<i>3</i>	L ₃	<i>4</i>	L ₄	<i>5</i>	L ₅	PYTHAGORAS
1	0	22.3	72	21	120	20.8	170	22.0	28.8	23.5	49.06

(R ₁) AND (α)	Percentage Error In Resultant And Angles	TOTAL %ERROR IN
------------------------------------	--	-----------------

Sr. No.	F=SUM F	α	$A = \frac{R-F}{R} \times 100$	$B = \frac{\theta 5 - \alpha}{\theta 5} \times 100$	(B-A)
1	1.250 KG	72	97.45	75	22.45

EXPERIMENT NO-9

SCREW JACK APPARATUS

Machine: It is a device which is use for doing a particular work from receives energy in some available form.

Lifting Machine: It is a device which is use to overcome a force or load (W) applied at one point by mean of another force called effort (P).

Types of Machine:

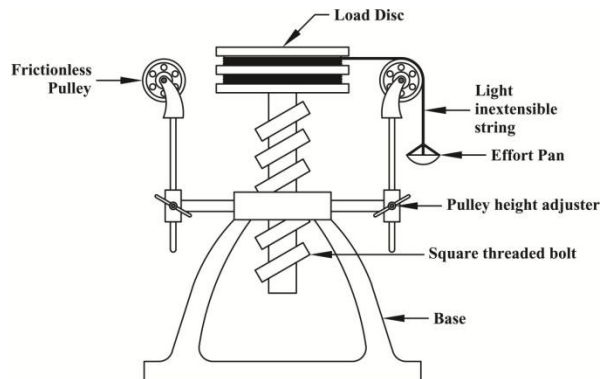

1. Simple machine
2. Compound machine

- **Simple Machine:** Have only one point for the application of effort and one point for load. eg: Lever, screw jack etc.
- **Compound Machine:** has more than one point for the application of effort and for load. eg: Printing machine, milling machine, planer, shaper etc

IMPORTANT TERMS

- **Mechanical advantage of a machine (M.A.):** It is the ratio of the weight lifted (W) to the effort applied (P).
- $M.A. = W/P$
- **Velocity ratio (V.R.):** It is the ratio of the distance (y) moved by the effort to the distance (x) moved by the load.
- $V.R = y/x$
- **Input of a machine:** It is the work done on the machine. In a lifting machine, it is measured by the product of effort and the distance through which it has moved (i.e., P.y).
- **Output of a machine:** It is the actual work done by the machine. In a lifting machine it is measured by the product of the weight lifted and the distance through which it has been lifted i.e., (W.x).
- **Efficiency of a machine (η):** It is the ratio of output to the input of a machine.
- $\eta = \text{Output/Input}$
- **Ideal machine:** A machine is said to be ideal if its efficiency is 100%. In this case, output is equal to input.

Whereas:

W= Load lifted by the machine;

P = Effort required to lift the load;

y = Distance moved by the effort, in lifting the load;

x = Distance moved by the load;

η = Efficiency of the machine.

SIMPLE SCREW JACK

It is a device employed for lifting heavy loads which are usually centrally loaded upon it. Horizontal power is applied with the lever (or handle).

Formula Used

Let L = Length of lever (or power arm)

P = The effort applied

W= The load lifted

p = Pitch of the screw

Suppose, screw has taken one full revolution,

Distance moved by the load = p

Distance moved by the effort = $2\pi L$

V.R. = (Distance moved by P) / (Distance moved by W) = $2\pi L / p$

If the screw is double threaded then for one revolution of power arm the load will be lifted up through twice the pitch.

Hence, V.R. for double threaded screw, $V.R = 2\pi L / 2p = \pi L / p$

M.A = W / P

$\eta = M.A / V.R$

Procedure:

1. Firstly stabilize the simple screw jack machine and wrap the cord around the load drum and pass it over the pulley.
2. Put some weight on the load drum. And add the some effort to the effort hanger on the pulleys.
3. Hit the machine with some material, thus you will see some kind of movement in the load drum.
4. Write down the initial reading in the observation table.
5. After taking the initial reading we put the some load on the load drum.
6. After this just increase the effort on the effort pulleys (either to the left or to the right)
7. Again hit the machine with some material, thus you will see another movement in the load drum.
8. Write down the second reading in the observation table.
9. After this apply the above procedure, four to five times with gradually increasing the Load as well as Effort to the load drum and effort pulley respectively.
10. Write down the all reading in the given observation table.
11. Measure the radius of the load drum and pitch of screw.
12. Calculate the MA, VR and η of machine.

Observation table:

S.No.	Load (W) in gram.	Effort (P) in gram.
P_A	P_B	$P = P_A + P_B$
1.		
2.		
3.		
4.		
5.		

Precautions:

1. Lubricate the screw before starting the experiment.
2. Trapping should be done after adding the weight in the effort hanger.
3. Overlapping of string should not be there.

Source of error:

1. Frictions in the pulley.
2. Effort being pulled suddenly.

Result: The efficiency of the simple screw jack is.....

EXPERIMENT NO-10

COMPOUND PENDULUM

Aim: (i) To determine the acceleration due to gravity (g) by means of a compound pendulum.

(ii) To determine radius of gyration about an axis through the center of gravity for the compound pendulum.

Apparatus and Accessories: (i) A bar pendulum, (ii) a knife-edge with a platform, (iii) a spirit level, (iv) a precision stop watch, (v) a meter scale and (vi) a telescope.

Theory:

A simple pendulum consists of a small body called a “bob” (usually a sphere) attached to the end of a string the length of which is great compared with the dimensions of the bob and the mass of which is negligible in comparison with that of the bob. Under these conditions the mass of the bob may be regarded as concentrated at its center of gravity, and the length of the pendulum is the distance of this point from the axis of suspension. When the dimensions of the suspended body are not negligible in comparison with the distance from the axis of suspension to

the center of gravity, the pendulum is called a compound, or physical, pendulum. A rigid body mounted upon a horizontal axis so as to vibrate under the force of gravity is a compound pendulum.

In Fig.1 a body of irregular shape is pivoted about a horizontal frictionless axis through P and is displaced from its equilibrium position by an angle θ . In the equilibrium position the center of gravity G of the body is vertically below P. The distance GP is l and the mass of the body is m . The restoring torque for an angular displacement θ is

$$\tau = -mg l \sin\theta \quad \dots(1)$$

For small amplitudes ($\theta \approx 0$),

$$I \frac{d^2\theta}{dt^2} = -mg l \theta, \quad \dots(2)$$

where I is the moment of inertia of the body through the axis P. Eq. (2) represents a simple harmonic motion and hence the time period of oscillation is given by

$$T = 2\pi \sqrt{\frac{I}{mg l}} \quad \dots(3)$$

Now $I = I_G + ml^2$, where I_G is the moment of inertia of the body about an axis parallel with axis of oscillation and passing through the center of gravity G.

$$I_G = mK^2 \quad \dots(4)$$

where K is the radius of gyration about the axis passing through G. Thus,

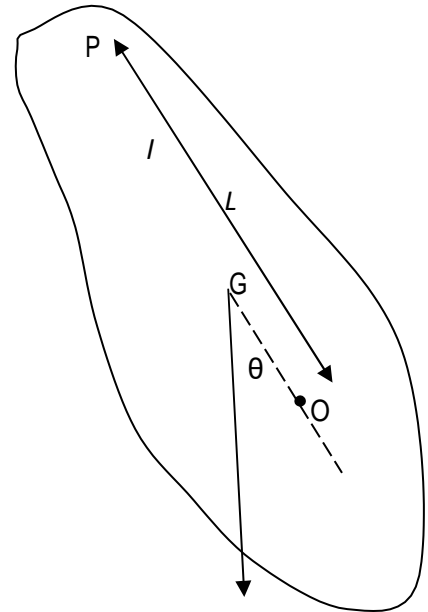

Fig. 1

$$T = \frac{2\pi \sqrt{K^2 + S^2}}{g} = 2\pi \sqrt{\frac{K^2}{g}} \quad \dots(5)$$

The time period of a simple pendulum of length L , is given by

$$T = 2\pi \sqrt{\frac{L}{g}} \quad \dots(6)$$

Comparing with Eq. (5) we get

$$L = 1 + \frac{K^2}{S} \quad \dots(7)$$

This is the length of “equivalent simple pendulum”. If all the mass of the body were concentrated at a point O (See Fig.1) such that $OP = k^2 + 1$, we would have a simple pendulum with the same time period. The point O is called the ‘Centre of Oscillation’. Now from Eq. (7)

$$l^2 - lL + K^2 = 0 \quad \dots(8)$$

i.e. a quadratic equation in l . Equation 6 has two roots l_1 and l_2 such that

$$\text{and} \quad \begin{aligned} l_1 + l_2 &= L \\ l_1 l_2 &= K^2 \end{aligned} \quad \dots(9)$$

Thus both l_1 and l_2 are positive. This means that on one side of C.G there are two positions of the centre of suspension about which the time periods are the same. Similarly, there will be a pair of positions of the centre of suspension on the other side of the C.G about which the time periods will be the same. Thus there are four positions of the centers of suspension, two on either side of the C.G, about which the time periods of the pendulum would be the same. The distance between two such positions of the centers of suspension, asymmetrically located on either side of C.G, is the length L of the simple equivalent pendulum. Thus, if the body was supported on a parallel axis through the point O (see Fig. 1), it would oscillate with the same time period T as when supported at P. Now it is evident that on either side of G, there are infinite numbers of such pair of points satisfying Eq. (9). If the body is supported by an axis through G, the time period of oscillation would be infinite. From any other axis in the body the time period is given by Eq. (5). From Eq.(6) and (9), the value of g and K are given by

$$g = 4\pi^2 \frac{L}{T^2} \quad \dots(10)$$

$$K = \sqrt{l_1 l_2} \quad \dots(11)$$

By determining L , l_1 and l_2 graphically for a particular value of T , the acceleration due to gravity g at that place and the radius of gyration K of the compound pendulum can be determined.

Description:

The bar pendulum consists of a metallic bar of about one meter long. A series of circular holes each of approximately 5 mm in diameter are made along the length of the bar. The bar is suspended from a horizontal knife-edge passing through any of the holes (Fig. 2). The knife-edge, in turn, is fixed in a platform provided with the screws. By adjusting the rear screw the platform can be made horizontal.

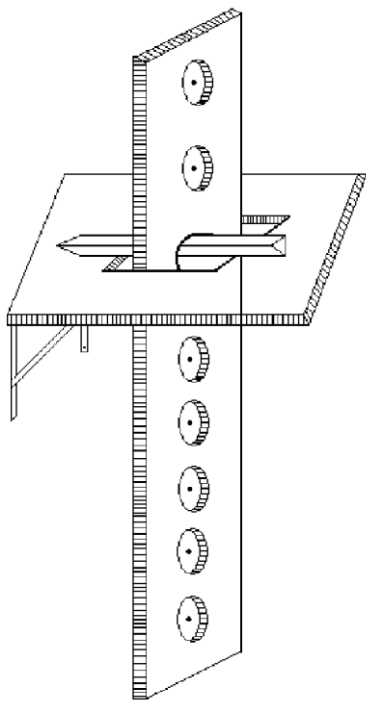

Fig. 2

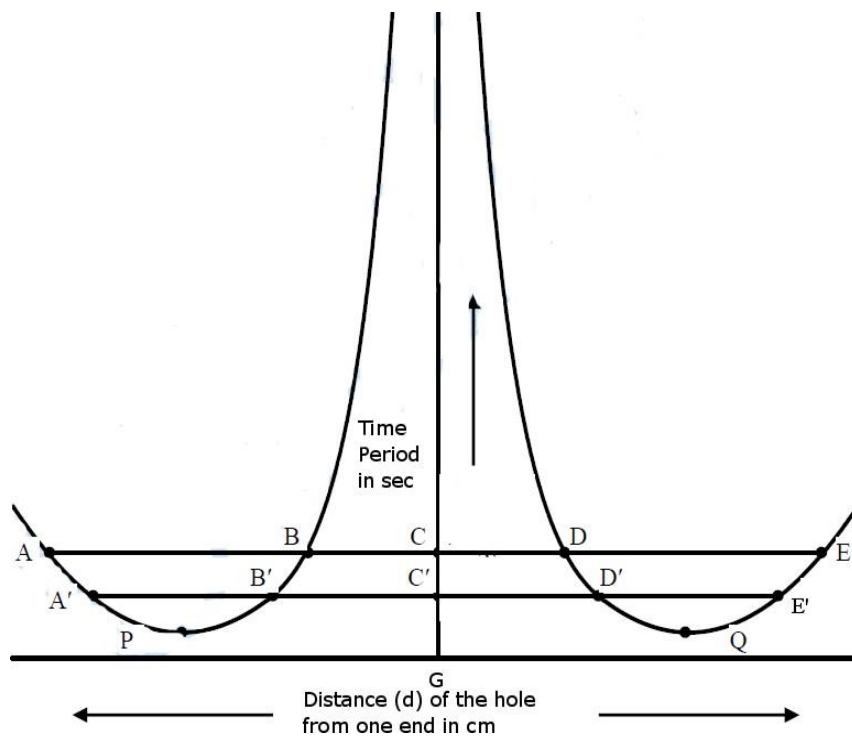

Fig. 3

Procedure:

- (i) Suspend the bar using the knife edge of the hook through a hole nearest to one end of the bar. With the bar at rest, focus a telescope so that the vertical cross-wire of the telescope is coincident with the vertical mark on the bar.
- (ii) Allow the bar to oscillate in a vertical plane with small amplitude (within 4° of arc).
- (iii) Note the time for 20 oscillations by a precision stop-watch by observing the transits of the vertical line on the bar through the telescope. Make this observation three times and find the mean time t for 20 oscillations. Determine the time period T .
- (iv) Measure the distance d of the axis of the suspension, i.e. the hole from one of the edges of the bar by a meter scale.
- (v) Repeat operation (i) to (iv) for the other holes till C.G of the bar is approached where the time period becomes very large.

(vi) Invert the bar and repeat operations (i) to (v) for each hole starting from the extreme top.

(vii) Draw a graph with the distance d of the holes as abscissa and the time period T as ordinate. The nature of graph will be as shown in Fig. 3.

Draw the horizontal line ABCDE parallel to the X-axis. Here A, B, D and E represent the point of intersections of the line with the curves. Note that the curves are symmetrical about a vertical line which meets the X-axis at the point G, which gives the position of the C.G of the bar. This vertical line intersects with the line ABCDE at C. Determine the length AD and BE and find the length L of the equivalent simple pendulum from $L = \frac{AD+BE}{2} = \frac{LX}{2}$.

Find also the time period T corresponding to the line ABCDE and then compute the value of g . Draw several horizontal lines parallel to X-axis and adopting the above procedure find the value of g for each horizontal line. Calculate the mean value of g . Alternatively, for each horizontal line obtain the values of L and T and draw a graph with T^2 as abscissa and L as ordinate. The graph would be a straight line. By taking a convenient point on the graph, g may be calculated.

Similarly, to calculate the value of K , determine the length AC, BC or CD, CE of the line ABCDE and compute $\sqrt{AC \times BC}$ or $\sqrt{CD \times CE}$. Repeat the procedure for each horizontal line. Find the mean of all K .

Observations:

Table 1-Data for the T versus d graph

Serial no of holes from one end	Distance d of the hole from one end (cm)	Time for 20 oscillations (sec)	Mean time t for 20 oscillations (sec)	Time period $T = t/20$ (sec)
One side of C.G	1
	2
	3
Other side of C.G	1
	2
	3

TABLE 2- The value of g and K from T vs. d graph

No. of obs.	L (cm)	T (sec)	$g = 4n^2 \frac{L}{T^2}$ (cm/sec ²)	Mean 'g' (cm/sec ²)	K (cm)	Mean 'K' (cm)
1. ABCDE	(AD+BE)/2		\sqrt{ACXBC} or	
2.		\sqrt{CDXC}	
3.		E	

Computation of proportional error:

We have from Eq. (10)

$$g = 4n^2 \frac{L}{(L_x/2)^2} \quad \dots(12)$$

Since $L = L_x/2$ ($L_x = AD+BE$) and $T = t/20$, therefore, we can calculate the maximum proportional error in the measurement of g as follows

$$\frac{\delta g}{g} = \mathbf{J} \left(\frac{\delta L_x}{L_x} \right)^2 + \left(2 \frac{\delta t}{t} \right)^2 \quad \dots (13)$$

δL_s = the value of the smallest division of the meter scale

δt = the value of the smallest division of the stop-watch

Precautions and Discussions:

- (i) Ensure that the pendulum oscillates in a vertical plane and that there is no rotational motion of the pendulum.
- (ii) The amplitude of oscillation should remain within 4° of arc.
- (iii) Use a precision stop-watch and note the time accurately as far as possible.
- (iv) Make sure that there is no air current in the vicinity of the pendulum.

EXPERIMENT NO-11

OBJECTIVE-

To determine the mechanical advantage, velocity ratio and efficiency of a worm and worm wheel.

APPARATUS REQUIRED-

- Worm and worm wheel Apparatus.
- Conical Weight

THEORY-

- As the pulley of the worm moves through n revolutions, n teeth of the wheel pass completely through the worm. If there are N teeth in pulley of the worm to rotate completely the worm moves through N revolution the load is raised up by the a distance equal to the length of the circumference of the pulley of the worm wheel.

So that velocity ratio is

$$\frac{N \times \text{circumference of pulley of worm}}{\text{Circumference of pulley of worm wheel}}$$

PROCEDURE-

- Wrap the string round the pulley of the worm the free end of which is to be tied to the effort.
- Wrap another string to carry the load the pulley the worm wheel in such a manner that as the effort is applied the is lifted up.
- Suspend a small weight (w) through the free string, which should just move the load upward.
- Note w and p. so that mechanical advantage is given by W/P.
- Increase the load (w) gradually and increase the effort (p) correspondingly and take in this way about seven readings.
- Measure the circumference of the pulley of the worm and also that of the worm wheel.
- The percentage efficiency is given by
$$= \frac{W * 100}{PV}$$
- Plot a graph between w and p and w and.

OBSERVATION -

Circumference of pulley of the

worm (2 π R1)= _____ cm. Circumference of pulley of the worm v

Velocity ratio =
$$\frac{N \times 2 \pi R1}{2 \pi R2}$$

OBSERVATION TABLE-

RESULTS AND DISCUSSION-

EXPERIMENT NO-12

Experiment: To determine the efficiency of a wheel and differential axle and to plot a graph between W and P and (w and n)

Things required:

1. Wheel & Differential Axle Apparatus

2. Weights
3. Cotton Thread

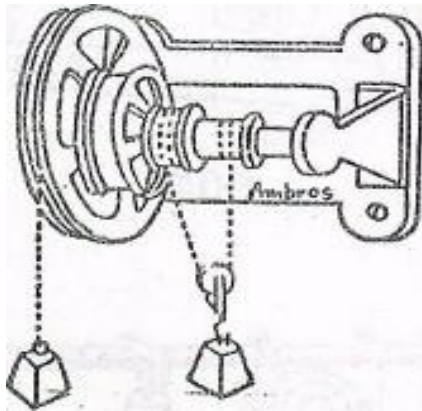

Theory:

When the wheel moves through n revolutions the bigger and smaller axles also move through “ n ” revolutions. But while the string carrying weight is wrapped round the bigger axle completely it is released completely from the smaller axle the same time if the radius of the bigger axle is r_1 and smaller axle is r_2 then the string of length $nr(2r_1)$ is raised while a length $nr(2r_2)$ is lowered so that weight (w) which is supported by two segments of string is raised through a distance $(2r_1 - 2r_2) \times n$: while distance moved by the effort is $2R \times n$

Velocity Ratio (v) is $\frac{2r \times n}{(2r_1 - 2r_2) \times n} = \frac{2(2r)}{(2r_1 - 2r_2)}$ in term of the circumferences

Procedure::

1. Wrap the string round the smaller and bigger axles in such a manner that as it is released from the smaller axle in such a manner that is it released from the smaller axle it is wrapped round the bigger axle Tie another string round the wheel which will carry the effort applied.
2. Suspend a smaller weight (w) through the hook of a small pulley going in between the two segment of the string as show in the diagram.
3. Suspend another weight (p) is to act as effort to just raise the load (w)
4. Note the wt (w) and effort P so that mechanical advantage is w/p .
5. Increase the weight (w) by a small amount and go on increasing the effort P gradually till he load (w) is just raised. Take in this way about seven readings.
6. Measure the circumference of smaller and bigger axles and of the wheel also, so that velocity ratio (v) is determined.

7. The % age efficiency is given by $\frac{W \times 100}{PV}$

PV

Table:

S. No.	Weight Lifted (W)	Effort Applied (P)	Mech. Adv. = W/P	Velocity Ratio	% Efficiency W/PV x 100
1					
2					
3					
4					
5					
6					
7					
8					

Precautions:

1. Note the value of F when the motion just begins and the fly wheel does not move with any acceleration
2. Oil the bearings to reduce friction.
3. Overlapping of the string should be avoided.